

深圳市华显美科技有限公司

Shenzhen Huaxi anmei Technology Co., Ltd.

PRODUCT SPECIFICATIONS

For Customer: _____ : APPROVAL FOR SPECIFICATION

Customer Model No. _____ : APPROVAL FOR SAMPLE

Module No.: SQ101AB4EI317-39R501 Date :2021.03.09

Version :0

For Customer's Acceptance:

Approved By	Comment

PREPARED	CHECKED	VERIFIED BY QA DEPT	VERIFIED BY R&D DEPT

深圳市华显美科技有限公司

Shenzhen Huaxi anmei Technology Co., Ltd.

Revision Record

Rev	Date	Sub-Model	Description of change
A	2021.03.09		Preliminary Product Specification was first issued.

深圳市华显美科技有限公司

Shenzhen Huaxi anmei Technology Co., Ltd.

Table of contents

NO.	Item	Page
1	General description	
2	Outline Dimension	
3	Electrical Specifications	
4	Optical characteristics	
5	Appendix	
6	PIN Assignment	
7	Absolute Maximum Ratings	
8	Reliability Test Items	
9	Quality Level	
10	Precautions For Use Of LCD Modules	
11	Package	

深圳市华显美科技有限公司

Shenzhen Huaxi anmei Technology Co., Ltd.

1.0 GENERAL DESCRIPTION

1.1 DESCRIPTION

SQ101AB4EI317-39R501 is a color active matrix thin film transistor (TFT) IPS liquid crystal display (LCD) that uses amorphous silicon TFT as a switching device. It is composed of a TFT LCD panel, Driver IC ,FPC and Backlight.

1.2 FEATURES:

No.	Item	Specification	Unit
1	Panel Size	10.1"	inch
2	Number of Pixels	800 x3(RGB) x 1280	pixels
3	Active Area	135.360(W)x216.576(H)	mm
4	Pixel Pitch	0.1692 x 0.1692	mm
5	OutlineDimension	228.6(W) x 143(H) x2.60(D) mm	
6	Number of Colors	16.7M	-
7	Display Mode	Normally Black	-
8	ViewingDirection	IPS	
9	Pixel Arrangement	RGB vertical stripe	-
10	Luminance (cd/m ²)	250(TYP.)	nit
11	Contrast Ratio	1000(TYP.)	
12	Surface Treatment	Anti-glare	-
13	Interface	MIPI	-
14	Backlight	White LED	-
15	Operation Temperature	-10~50	°C
16	Storage Temperature	-20~60	°C
17	Driver IC	JD9365DA-H3	-

深圳市华显美科技有限公司

Shenzhen Huaxi anmei Technology Co., Ltd.

2. Outline Dimension

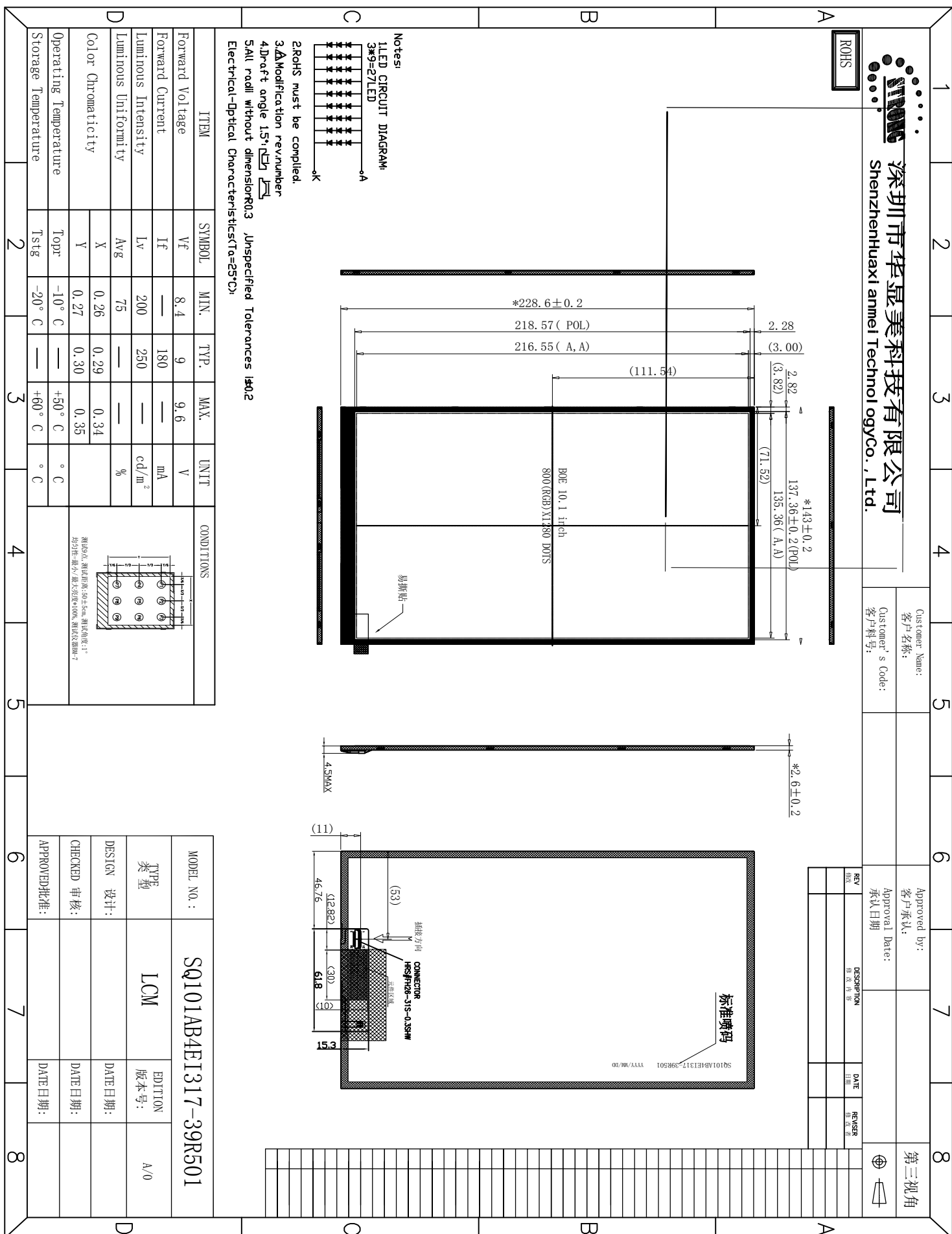

深圳市华显美科技有限公司

Shenzhen Huaxianmei Technology Co., Ltd.

3.0 ELECTRICAL SPECIFICATIONS

3.1 Electrical Specifications

< Table 3. LCD Module Electrical Specifications >

[Ta =25± 2 °C]

Parameter	Symbol	Value	Unit	Remarks
TFT Gate ON Voltage	VGH	15	V	
TFT Gate OFF Voltage	VGL	-11	V	
Analog Power Supply Voltage	AVDD/AV EE	5/-5	V	

深圳市华显美科技有限公司

Shenzhen Huaxi anmei Technology Co., Ltd.

4.0 OPTICAL SPECIFICATION

4.1 Overview

The test of Optical specifications shall be measured in a dark room (ambient luminance $\leq 1\text{lux}$ and temperature = $25\pm 2^\circ\text{C}$) with the equipment of Luminance meter system (Goniometer system and TOPCON BM-5) and test unit shall be located at an approximate distance 50cm from the LCD surface at a viewing angle of θ and Φ equal to 0° . We refer to $\theta\phi=0$ ($=\theta_3$) as the 3 o'clock direction (the "right"), $\theta\phi=90$ ($=\theta_{12}$) as the 12 o'clock direction ("upward"), $\theta\phi=180$ ($=\theta_9$) as the 9 o'clock direction ("left") and $\theta\phi=270$ ($=\theta_6$) as the 6 o'clock direction ("bottom"). While scanning θ and /or ϕ , the center of the measuring spot on the Display surface shall stay fixed. The backlight should be operating for 30 minutes prior to measurement. VDD shall be $3.3\pm 0.3\text{V}$ for LVDS interface or $1.8\pm 0.09\text{V}$ for MIPI interface at 25°C .

4.2 Optical Specifications

<Table 5. Optical Specifications>

Parameter		Symbol	Condition	Min.	Typ.	Max.	Unit	Remark
Viewing Angle range	Horizontal	θ_3	CR > 10	80	85	-	Deg.	Note 1
		θ_9		80	85	-	Deg.	
	Vertical	θ_{12}		80	85	-	Deg.	
		θ_6		80	85	-	Deg.	
Color Gamut (C light)				-	53	-	%	
Luminance Contrast ratio		CR	$\theta = 0^\circ$	700	1000			Note 2
Transmittance		T(%)	$\theta = 0^\circ$	5.85	6.5	7.15	%	Base on C Light Note 3
White Chromaticity		x_w	$\theta = 0^\circ$	0.270	0.300	0.330		Note 4 C light
		y_w		0.329	0.359	0.389		
Reproduction of color (C light)	Red	x_R	$\theta = 0^\circ$	0.610	0.640	0.670		
		y_R		0.315	0.345	0.375		
	Green	x_G		0.241	0.271	0.301		
		y_G		0.531	0.561	0.591		
	Blue	x_B		0.107	0.137	0.167		
		y_B		0.147	0.177	0.207		
Response Time (Rising + Falling)		T_{RT}	Ta= 25°C $\theta = 0^\circ$	-	30	35	ms	Note 5

深圳市华显美科技有限公司

Shenzhen Huaxi anmei Technology Co., Ltd.

- Notes :
1. Viewing angle is the angle at which the contrast ratio is greater than 10. The viewing angles are determined for the horizontal or 3, 9 o'clock direction and the vertical or 6, 12 o'clock direction with respect to the optical axis which is normal to the LCD surface (see FIGURE 1).
 2. Contrast measurements shall be made at viewing angle of $\Theta = 0$ and at the center of the LCD surface. Luminance shall be measured with all pixels in the view field set first to white, then to the dark (black) state . (see FIGURE 1) Luminance Contrast Ratio (CR) is defined mathematically.

$$CR = \frac{\text{Luminance when displaying a white raster}}{\text{Luminance when displaying a black raster}}$$

3. Transmittance is the Value with Polarizer
4. The color chromaticity coordinates specified in Table 5 shall be calculated from the spectral data measured with all pixels first in red, green, blue and white. Measurements shall be made at the center of the panel.
5. The electro-optical response time measurements shall be made as FIGURE 3 by switching the "data" input signal ON and OFF. The times needed for the luminance to change from 10% to 90% is T_r , and 90% to 10% is T_d .

深圳市华显美科技有限公司

Shenzhen Huaxi anmei Technology Co., Ltd.

5.0 APPENDIX

Figure 2. The Definition of V_{th} & V_{sat}

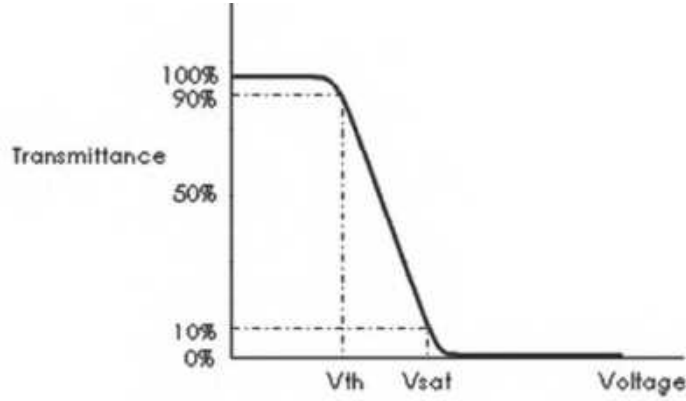

Figure 3. Measurement Set Up

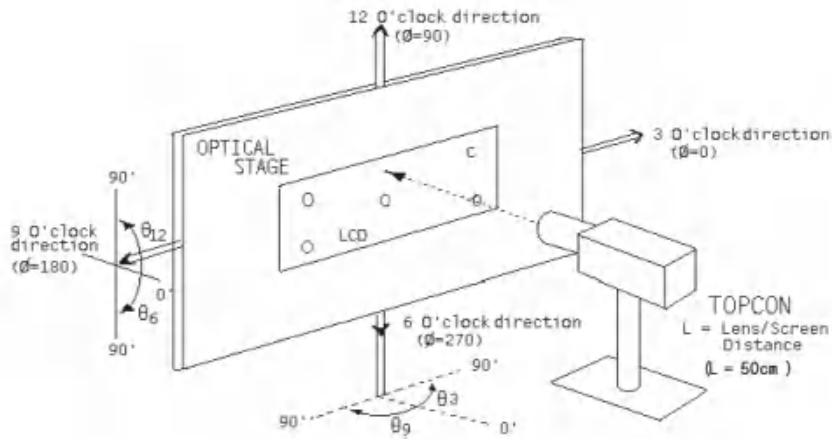
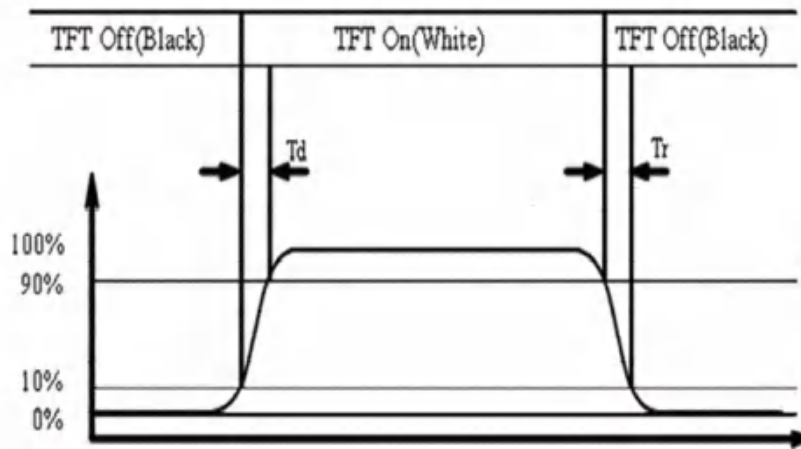

Figure 4. Response Time Testing



深圳市华显美科技有限公司

Shenzhen Huaxi anmei Technology Co., Ltd.

Figure 6-2. TFT-LCD Panel Test 时序

CT Pad Name	V1 (V)	V2 (V)	Width (us)	Period (us)
GO	VGL(-11V)	VGH (15V)	8333.5	16667
GE	VGL(-11V)	VGH (15V)	8333.5	16667
GS	15V	15V	0	0
DS	15V	15V	0	0
VCOM	VCOM	VCOM	0	0
DM	Data H	Data L	8333.5	16667
DY	Data H	Data L	8333.5	16667
DC	Data H	Data L	8333.5	16667

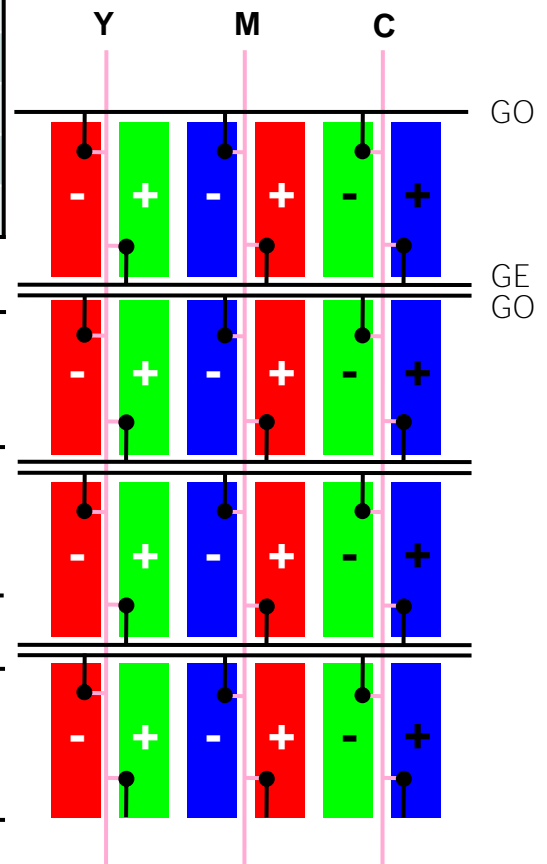
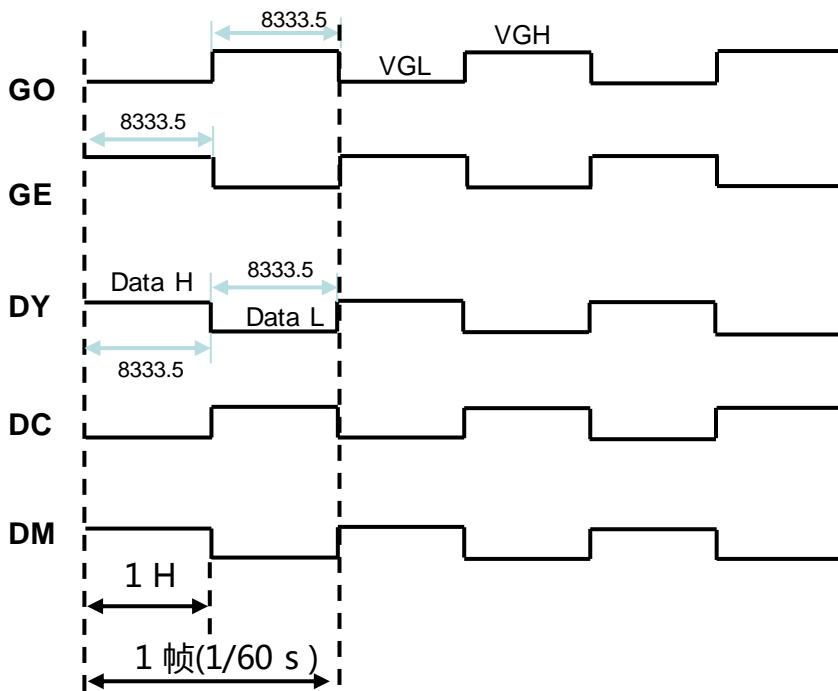

■ 以上为检查某灰阶画面(DY, DC, DM 同时开启)的波形设置

■ 为提升检出率电压可调整

■ 比如VCOM=2.8 V, Data H=4.2 V, Data L=0 V

■ 对应左图在前H/2时的像素开启情况(+ 表示有电压写入; - 表示电压同Vcom电压)

深圳市华显美科技有限公司

Shenzhen Huaxi anmei Technology Co., Ltd.

6.0 PIN Assignment

PIN NO.	Symbol	Description	Remarks
1	LED+	Power supply for LED (Anode)	
2	LED+	Power supply for LED (Anode)	
3	LED+	Power supply for LED (Anode)	
4	NC	No Connect	
5	LED-	Power supply for LED (Cathode)	
6	LED-	Power supply for LED (Cathode)	
7	LED-	Power supply for LED (Cathode)	
8	LED-	Power supply for LED (Cathode)	
9	GND	Ground	
10	GND	Ground	
11	MIPI_2P	MIPI data positive signal (2P)	
12	MIPI_2N	MIPI data positive signal (2N)	
13	GND	Ground	
14	MIPI_1P	MIPI data positive signal (1P)	
15	MIPI_1N	MIPI data positive signal (1N)	
16	GND	Ground	
17	MIPI_CLKP	MIPI CLK positive signal (CLKP)	
18	MIPI_CLKN	MIPI CLK positive signal (CLKN)	
19	GND	Ground	
20	MIPI_OP	MIPI data positive signal (OP)	
21	MIPI_ON	MIPI data positive signal (ON)	
22	GND	Ground	
23	MIPI_3P	MIPI data positive signal (3P)	
24	MIPI_3N	MIPI data positive signal (3N)	
25	GND	Ground	
26	NC	No Connect	
27	RESET	Reset Pin	
28	GND	Ground	
29	VDDIO	Logic power 1.8V	
30	VDD	Logic power 3.3V	
31	VDD	Logic power 3.3V	

深圳市华显美科技有限公司

Shenzhen Huaxi anmei Technology Co., Ltd.

7.0 ABSOLUTE MAXIMUM RATINGS

7.1 Environment Absolute Rating

Item	Storage		Operating		Note
	MIN.	MAX.	MIN.	MAX.	
Ambient Temperature	-20°C	60°C	-10°C	50°C	1,2
Humidity	-	-	-	-	3

1. The response time will become lower when operated at low temperature.
2. Background color changes slightly depending on ambient temperature.

The phenomenon is reversible.

7.2 LED backlight specification(VSS=0V ,Ta=25°C)

Item	Symbol	Condition	Min	Typ	Max	Unit	Note
Supply voltage	-	-	-	9.0	-	V	1
Supply current	I _f	-	-	180	-	mA	2
Forward current	Normal	3-chip series x 9	-	-	-	mA	
	Dimming		I _{pd}	-	-		

深圳市华显美科技有限公司

Shenzhen Huaxi anmei Technology Co., Ltd.

8.0 RELIABILITY SPECIFICATION

8.0.1 TEMPERATURE AND HUMIDITY

Test Item	Test Condition	Remark
High Temperature Storage	Ta=60°C; 72hrs	IEC60068-2-1: 2007 GB2423.2-2008
Low Temperature Storage	Ta=-20°C; 72hrs	IEC60068-2-1: 2007 GB2423.1-2008
High Temperature Operation	Ta=50°C; 72hrs	IEC60068-2-1: 2007 GB2423.2-2008
Low Temperature Operation	Ta=-10°C; 72hrs	IEC60068-2-1: 2007 GB2423.1-2008
High Temperature High Humidity Operation	Ta=50°C, 90%RH, 72Hrs(no condensation)	IEC60068-2-78: 2001 GB/T2423.3-2006
Thermal Shock	-20°C(0.5h) ~ 60°C(0.5h) / 10cycles	Start with cold temperature , End with high temperature, IEC60068-2-14:1984,GB2423.22-2002
Image Sticking	25°C ; 2hrs	Note1

Note1:Condition of image sticking test :25°C ±2°C

Operation with test pattern sustained for 2hrs,then change to gray pattern immediately.after5 mins,themura must be disappeared completely

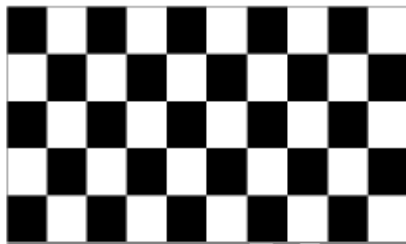

(a) Test Pattern (chess board Pattern)



(b) Gray Pattern

8.0.2ESD

Test item	Conditions	Remark	
Electro Static Discharge Test (non-operation)	150pF, 330Ω, Contact:±3KV,Air:±8KV	1	IEC61000-4-2: 2001 GB/T17626.2-2006
	200pF, 0Ω, ±200V contact test	2	

Note: Measure point :

1. LCD glass and metal bezel
2. IF connector pins

深圳市华显美科技有限公司

Shenzhen Huaxi anmei Technology Co., Ltd.

8.1 Use Restriction

This product is not authorized for use in life supporting systems, aircraft navigation control systems, military systems and any other application where performance failure could be life threatening or otherwise catastrophic.

8.2 Disassembling or Modification

Do not disassemble or modify the module. It may damage sensitive parts inside LCD module, and may cause scratches or dust on the display. HannStar does not warrant the module, if customers disassemble or modify the module.

8.3 Breakage of LCD Panel

8.3.1. If LCD panel is broken and liquid crystal spills out, do not ingest or inhale liquid crystal, and do not contact liquid crystal with skin.

8.3.2. If liquid crystal contacts mouth or eyes, rinse out with water immediately.

8.3.3. If liquid crystal contacts skin or cloths, wash it off immediately with alcohol and rinse thoroughly with water.

8.3.4. Handle carefully with chips of glass that may cause injury, when the glass is broken.

8.4 Electric Shock

8.4.1. Disconnect power supply before handling LCD module.

8.4.2. Do not pull or fold the LED cable.

8.4.3. Do not touch the parts inside LCD modules and the fluorescent LED's connector or cables in order to prevent electric shock.

8.5 Absolute Maximum Ratings and Power Protection Circuit

8.5.1. Do not exceed the absolute maximum rating values, such as the supply voltage variation, input voltage variation, variation in parts' parameters, environmental temperature, etc., otherwise LCD module may be damaged. 9.5.2. Please do not leave LCD module in the environment of high humidity and high temperature for a long time. 11.5.3. It's recommended to employ protection circuit for power supply.

8.6 Operation

8.6.1 Do not touch, push or rub the polarizer with anything harder than HB pencil lead.

8.6.2 Use fingerstalls of soft gloves in order to keep clean display quality, when persons handle the LCD module for incoming inspection or assembly.

深圳市华显美科技有限公司

Shenzhen Huaxi anmei Technology Co., Ltd.

8.6.3 When the surface is dusty, please wipe gently with absorbent cotton or other soft material.

8.6.4 Wipe off saliva or water drops as soon as possible. If saliva or water drops contact with polarizer for a long time, they may causes deformation or color fading.

8.6.5 When cleaning the adhesives, please use absorbent cotton wetted with a little petroleum benzine or other adequate solvent.

8.7 Mechanism

Please mount LCD module by using mouting holes arranged in four corners tightly.

8.8 Static Electricity

8.8.1 Protection film must remove very slowly from the surface of LCD module to prevent from electrostatic occurrence.

8.8.2. Because LCD module use CMOS-IC on circuit board and TFT-LCD panel, it is very weak to electrostatic discharge. Please be careful with electrostatic discharge. Persons who handle the module should be grounded through adequate methods.

8.9 Strong Light Exposure

The module shall not be exposed under strong light such as direct sunlight. Otherwise, display characteristics may be changed.

8.10 Disposal

When disposing LCD module, obey the local environmental regulations.

深圳市华显美科技有限公司

Shenzhen Huaxi anmei Technology Co., Ltd.

9 Quality level

9.1 Classification of defects

Major defects (MA): A major defect refers to a defect that may substantially degrade usability for product applications, including all functional defects (such as no display, abnormal display, open or missing segment, short circuit, missing component), outline dimension beyond the drawing, progressive defects and those affecting reliability.

Minor defects (MI): A minor defect refers to a defect which is not considered to be able to substantially degrade the product application or a defect that deviates from existing standards almost unrelated to the effective use of the product or its operation, such as black spot, white spot, bright spot, pinhole, black line, white line, contrast variation, glass defect, polarizer defect, etc.

9.2 Definition of inspection range

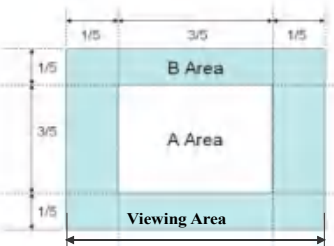
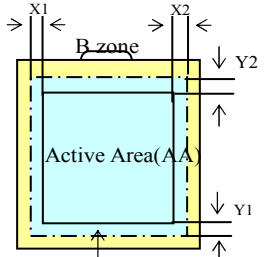
<p>For dot defect of TFT LCD which is not smaller than 3 inches, dividing three areas to make a judgment (according to figure 1).</p> <p>A area : center of viewing area B area : periphery of viewing area C area : Outside viewing area</p> <p>For other defects, dividing two areas to make a judgment (according figure 2).</p> <p>A zone : Inside Viewing area B zone : Outside Viewing area</p> <p>X1(A.A~V.A): 2mm X2(A.A~V.A): 2mm Y1(A.A~V.A): 2mm Y2(A.A~V.A): 2mm</p>	 <p style="text-align: center;">Figure 1</p>  <p style="text-align: center;">Figure 2</p>
--	--

9.3 Inspection items and general notes

General notes	<p>1. Should any defects which are not specified in this standard happen, additional standard shall be determined by mutual agreement between customer and TIANMA.</p> <p>2. Viewing area should be the area which TIANMA guarantees.</p> <p>3. Limit sample should be prior to this Inspection standard.</p> <p>4. Viewing judgment should be under static pattern.</p> <p>5. Inspection conditions</p> <p>Inspection distance: 250 mm (from the sample) Temperature : 25±5 °C</p> <p>Inspection angle : 45 degrees in 6 o'clock direction (all defects in viewing area should be inspected from this direction)</p>
---------------	--

深圳市华显美科技有限公司

Shenzhen Huaxi anmei Technology Co., Ltd.

Inspection items	Pinhole, Bright spot, Black spot, White spot, Black line, White Line, Foreign particle, Bubble	The color of a small area is different from the remainder. The phenomenon doesn't change with voltage
	Contrast variation	The color of a small area is different from the remainder. The phenomenon changes with voltage
	Polarizer defect	Scratch, Dirt, Particle, Bubble on polarizer or between polarizer and glass
	Dot defect (TFT LCD)	The pixel appears bright or dark abnormally when display
	Functional defect	No display, Abnormal display, Open or missing segment, Short circuit, False viewing direction
	Glass defect	Glass crack, Shaved corner of glass, Surplus glass
	PCB defect	Components assembly defect

9.4 Outgoing Inspection level

Outgoing Inspection standard	Inspection conditions	Inspection				
		Min.	Max	Unit	IL	AQL
Major Defects	See 8.3 general notes	See	8.5		II	0.065
Minor Defects	See 8.3 general notes	See	8.5		II	0.065

Note : Sampling standard conforms to GB2828

9.5 Inspection Items and Criteria

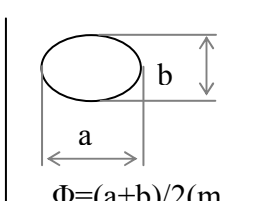
Inspection items		Judgment standard			
		Category	Acceptable number		
			A zone	B zone	
1	Black spot, White spot, Pinhole, Foreign Particle, Particle in or on glass, Scratch on glass 	A	$\Phi \leq 0.20$	Neglected	Neglected
		B	$0.20 < \Phi \leq 0.25$	3	Neglected
		C	$0.25 < \Phi \leq 0.3$	2	Neglected
		D	$0.3 < \Phi \leq 0.4$	1	3
		E	$0.4 < \Phi \leq 0.5$	0	2

深圳市华显美科技有限公司

Shenzhen Huaxi anmei Technology Co., Ltd.

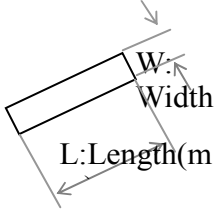
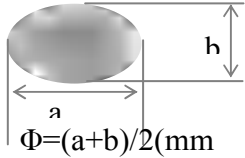
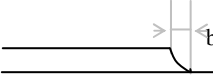
		(a/b<2.5)	Total defective point(B,C)		1	-
2	Black line, White line, and Particle Between Polarizer and glass, Scratch on glass	 L:Length(m) W:Width L/W>=2.5	A	W<=0.03	Neglected	Neglected
			B	0.03<W<=0.05 L<=3.0	3	Neglected
			C	0.05<W<=0.1 L<=3.0	2	Neglected
			D	0.05<W<=0.1 L<=4.0	1	3
			E	W>0.1 L>4.0	0	2
			Total defective point(B,C)		1	-
3	Bright spot		any size		none	none
4	Contrast variation	 a b $\Phi=(a+b)/2(\text{mm})$	A	$\Phi<0.2$	Neglected	Neglected
			B	$0.2<\Phi<=0.3$	2	
			C	$0.3<\Phi<=0.4$	1	
			D	$0.4<\Phi$	0	
			Total defective point(B,C)		3	
5	Bubble inside cell		any size		none	none
6	Polarizer defect (if Polarizer is used)	Scratch ,damage on polarizer, Particle on polarizer or between polarizer and glass.	Refer to item 1 and item 2.			
		Bubble, dent and convex	A	$\Phi<=0.1$	Neglected	Neglected
			B	$0.1 <\Phi<=0.2$	2	Neglected
			C	$0.2 <\Phi<=0.3$	1	2
7	Surplus glass	Stage surplus glass	 B<=0.3mm			

深圳市华显美科技有限公司

Shenzhen Huaxi anmei Technology Co., Ltd.

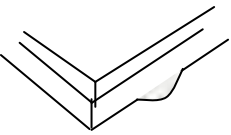
		<p>Surrounding surplus glass</p> 	Should not influence outline dimension and assembling.
8	Open segment or open common		Not permitted
9	Short circuit		Not permitted
10	False viewing direction		Not permitted
11	Contrast ratio uneven		According to the limit specimen
12	Crosstalk		According to the limit specimen
13	Black /White spot(display)		Refer to item 1
14	Black /White line(display)		Refer to item 2

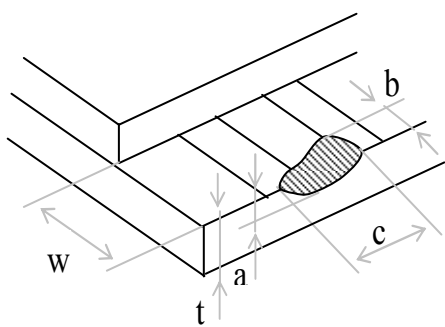
Inspection items		Judgment standard		Acceptable number	
		Category(application: B zone)			
15	Glass defect crack	<p>i) The front of lead terminals</p> 	A	$a \leq t$, $b \leq 1/5W$, $c \leq 3\text{mm}$	Max.3 defects allowed
			B	Crack at two sides of lead terminals should not cover patterns and alignment mark	

深圳市华显美科技有限公司

Shenzhen Huaxi anmei Technology Co., Ltd.

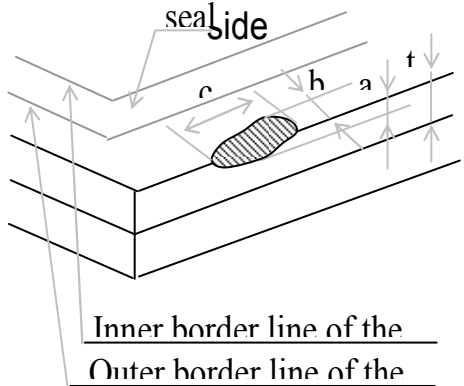
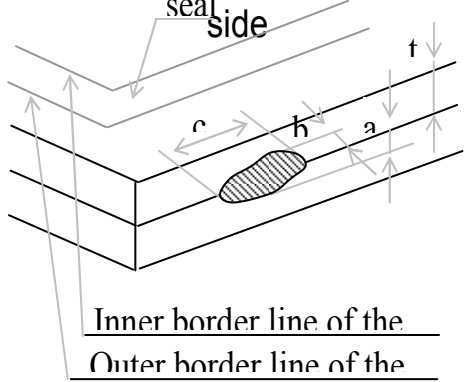
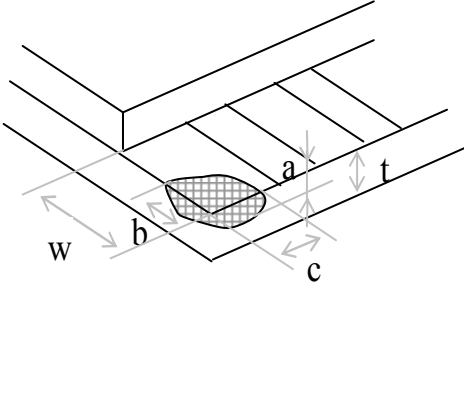
	<p>ii) Surrounding crack-non-contact</p>  <p>seal side</p> <p>Inner border line of the Outer border line of the</p>	<p>$b < \text{Inner borderline of the seal}$</p>					
	<p>iii) Surrounding crack-contact</p>  <p>seal side</p> <p>Inner border line of the Outer border line of the</p>	<p>$b < \text{Outer borderline of the seal}$</p>					
	<p>iv) Corner</p> 	<table border="1"> <tr> <td data-bbox="865 1191 916 1310">A</td> <td data-bbox="916 1191 1347 1310">$a \leq t, b \leq 3.0, c \leq 3.0$</td> </tr> <tr> <td data-bbox="865 1310 916 1709">B</td> <td data-bbox="916 1310 1347 1709">Glass crack should not cover patterns u and alignment mark and patterns.</td> </tr> </table>	A	$a \leq t, b \leq 3.0, c \leq 3.0$	B	Glass crack should not cover patterns u and alignment mark and patterns.	
A	$a \leq t, b \leq 3.0, c \leq 3.0$						
B	Glass crack should not cover patterns u and alignment mark and patterns.						

Inspection items	Judgment standard
	Category(application: B zone)

深圳市华显美科技有限公司

Shenzhen Huaxi anmei Technology Co., Ltd.

16	PCB defect	<p>Component soldering: No cold soldering 、 short 、 open circuit 、 burr 、 tin ball The flat encapsulation component position deviation must be less than 1/3 width of the pin (Pic.1) ; the sheet component deviation: Pin deviates from the pad and contact with the near components is not permitted (Pic.2)</p>	
		<p>lead defect: The lead lack must be less than 1/3 of its width; The lead burr must be less than 1/3 of the seam; Impurities connect with the near leads is not permitted</p>	
		<p>Connector soldering: Soldering tin is at contact position of the plug and socket is not permitted No foundation is scald Serious cave distortion on plug and socket contact pin is not permitted</p>	
		<p>Glue on root of the speaker receiver and motor lead: The insulative coat of the lead must join into the PCB; the protected glue must envelop to the insulative coat.</p>	

10. Precautions for Use of LCD Modules

10.1 Handling Precautions

10.1.1 The display panel is made of glass. Do not subject it to a mechanical shock by dropping it from a high place, etc.

10.1.2 If the display panel is damaged and the liquid crystal substance inside it leaks out, be sure not to get any in your mouth, if the substance comes into contact with your skin or clothes, promptly wash it off using soap and water.

10.1.3 Do not apply excessive force to the display surface or the adjoining areas since this may cause the color tone to vary.

10.1.4 The polarizer covering the display surface of the LCD module is soft and easily scratched. Handle this polarizer carefully.

10.1.5 If the display surface is contaminated, breathe on the surface and gently wipe it with a soft dry cloth. If still not completely clear, moisten cloth with one of the following solvents:

- Isopropyl alcohol
- Ethyl alcohol

Solvents other than those mentioned above may damage the polarizer. Especially, do not use the following:

- Water
- Ketone
- Aromatic solvents

10.1.6 Do not attempt to disassemble the LCD Module.

10.1.7 If the logic circuit power is off, do not apply the input signals.

10.1.8 To prevent destruction of the elements by static electricity, be careful to maintain an optimum work environment.

a. Be sure to ground the body when handling the LCD Modules.

深圳市华显美科技有限公司

Shenzhen Huaxi anmei Technology Co., Ltd.

- b. Tools required for assembly, such as soldering irons, must be properly ground.
- c. To reduce the amount of static electricity generated, do not conduct assembly and other work under dry conditions.
- d. The LCD Module is coated with a film to protect the display surface. Be care when peeling off this protective film since static electricity may be generated.

10.2 Storage precautions

10.2.1 When storing the LCD modules, avoid exposure to direct sunlight or to the light of fluorescent lamps.

10.2.2 The LCD modules should be stored under the storage temperature range. If the LCD modules will be stored for a long time, the recommend condition is:

Temperature : $0^{\circ}\text{C} \sim 40^{\circ}\text{C}$

Relatively humidity: $\leq 80\%$

10.2.3 The LCD modules should be stored in the room without acid, alkali and harmful gas.

10.3 The LCD modules should be no falling and violent shocking during transportation, and also should avoid excessive press, water, damp and sunshine.

深圳市华显美科技有限公司

Shenzhen Huaxi anmei Technology Co., Ltd.

11. PACKAGE DRAWING

